

5AX Rotary Table FAN⁺

All Features of Product
Line 500 Included

NEW



Swiss Rotary Table
Technology

05.2016

FANUC

FANUC ROBODRILL
CNC machining centers

pl LEHMANN[®]

**Short cycle times
of 0.22 sec / 90°**

High speed

**Extended travel in
Z- and X-direction**

More space

**High transport ca-
pacity up to 133 kg**

Heavy duty

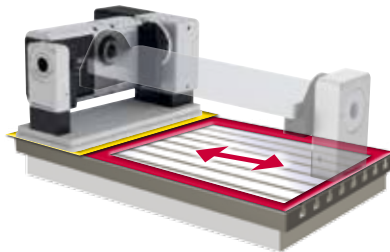

Interesting option: Optimal locating and space utilization allow the use of large clamping yokes for the efficient machining of multiple parts

FAN1

T1-507510 FAN standard

T1-508510 FAN high-speed (option)

ROBOTDRILL-standard



Save energy



Energy label on the right
An intuitive rating as consumption greatly depends on usage, and without any liability assumed, following the directives on energy labelling

Benefits of PGD by pL LEHMANN as compared to Direct Drive: small servo, low power draw, no cooling system, and a significantly reduced energy consumption when machining with unclamped rotary table.



High torque

**Feed torque up to
215 Nm**

Top flexibility

**Multifunctional
spindle HSK**

Top precision

**At the workpiece
up to 2 µm/100 mm**

**Pneum. clamping
up to 2'000 Nm**

High clamp

**Large parts up to
Ø 400**

Big size

**PGD backlash-free
long-life gear unit**

No backlash

High geometric accuracy (max. pivoting drift here:
10 µm on a 200-mm radius) is a prerequisite for
ultimate workpiece accuracy
(also applies to FAN1)

FAN2

T1-510520 FAN standard
T1-511520 FAN high-speed (option)



Steel base plate; overhanging ends
when mounted crosswise permitted
when mounted crosswise per instal-
lation proposal pL LEHMANN (also
for FAN1)

**Also for simulta-
neous operation**
(also applies to FAN1)

Worldwide

**25 countries:
worldwide service**

Never adjust

**Load change without
parameter adjust.**

Low cost

**No cooling
system required**

FAN1

Optimally located – maximum utilization of travel

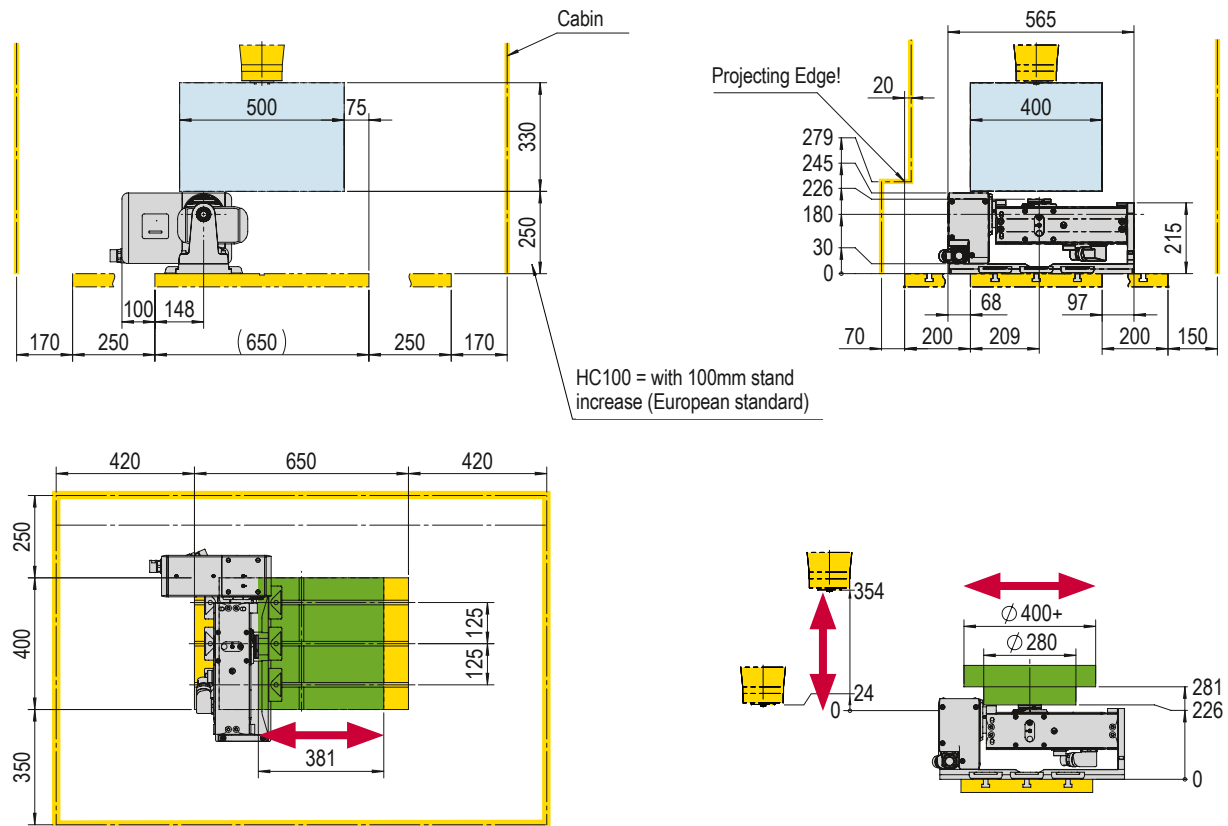

Technical Data

for FANUC motors (4th axis: β1is, 5th axis: α2 (hv)is)

				ROBODRILL-standard T1-507510	high-speed T1-508510	
Bearing / Clamping	kg	Total weight	with motor	kg	96	96
	Max clamping torque		4 th axis	Nm	300	300
			5 th axis	Nm	800	800
	Max spindle load		0°–30°	kg	80	80
			30°–90°	kg	53	53
			standard load	kg	17	8.5
Max axial force		4 th axis	kN	12	12	
		Max pull-out torque	4 th axis	Nm	1'200	1'200
Gear Unit			5 th axis	Nm	2'000	2'000
			Max moment of inertia	standard load	kgm ²	0.05
			J max	kgm ²	0.5	0.2
			Max feed torque	4 th axis	Nm	85
			5 th axis	Nm	135	135
			Pa *	4 th axis	± arc sec	20 / 12 / 2.5
			5 th axis	± arc sec	31 / 24 / 2.5	31 / 24 / 2.5
			Ps mid	4 th axis	± arc sec	2
			5 th axis	± arc sec	2	2
			Max speed with standard load	4 th axis	min ⁻¹	67
		5 th axis	min ⁻¹	45	45	
		Cycle time 90° min with standard load **	4 th axis	sec	0.30	0.22
		5 th axis	sec	0.48	0.48	

Swiveling axis (5th axis)



Dividing axis (4th axis)

* Standard / increased / WMS (angular position measuring system); can be compensated by pitch error

** Clamping will increase time by approx. 0.1 sec

FAN2

Optimally located – maximum utilization of travel

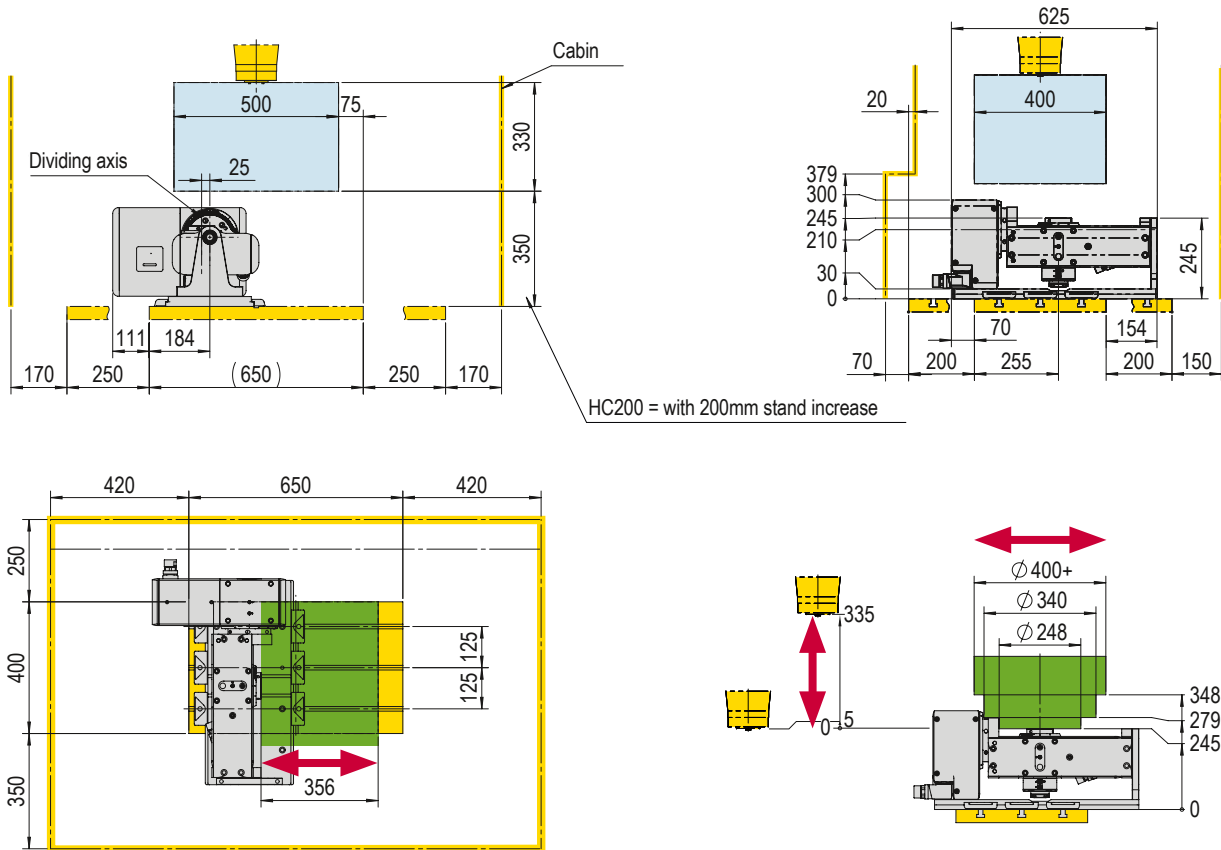

Technical Data

for FANUC motors (4th and 5th axis: α2 (hv)is)

				Standard T1-510520	high-speed T1-511520
Bearing / Clamping	kg Total weight	with motor		136	136
	Max clamping torque	4 th axis		800	600
		5 th axis		2'000	2'000
	Max spindle load	0°–30°		133	133
		30°–90°		89	85
		standard load		42	21
	Max axial force	4 th axis		20	20
		5 th axis		2'000	2'000
	Max pull-out torque	4 th axis		2'000	2'000
		5 th axis		3'900	3'900
Max moment of inertia	standard load		0.2	0.07	
	J max		2	0.7	
Max feed torque	4 th axis		135	90	
	5 th axis		215	215	
Gear Unit	Pa *	4 th axis		17 / 10 / 2.5	17 / 10 / 2.5
		5 th axis		21 / 17 / 2.5	21 / 17 / 2.5
	Ps mid	4 th axis		2	2
		5 th axis		2	2
	Max speed with standard load	4 th axis		55	100
		5 th axis		27	29
Cycle time 90° min with standard load **	4 th axis		0.34	0.24	
	5 th axis		0.76	0.61	

Swiveling axis (5th axis)



Dividing axis (4th axis)

* Standard / increased / WMS (angular position measuring system); can be compensated by pitch error

** Clamping will increase time by approx. 0.1 sec

More than 20 workpiece clamping systems



ripas

LANG
TECHNIK.de

EROWA

system 3R

SwissChuck
Precision Workholding

ROEMHELD
HILMA • STARK

SCHUNK

GRESSEL
Spanntechnik

PAROTEC
spanntechnik - robotik - engineering

tobler
a member of MORI SEIKI group

YERLY

NIEDERHAUSER
SPANNTECHNIK UND SYSTEME

AMF



T1-511520 – Impeller



T3-507510 – Large series

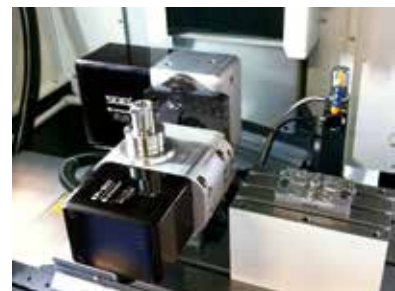

TF-510520 – Watch casings



TF-507510 – Bone implants



T1-507510 – Large parts



TF-507510 – Dental implants

Accurate – fast – efficient



Automotive



Medical / Dental



Watches /
Micro Technology



Eyewear / Jewelry



Mechanics

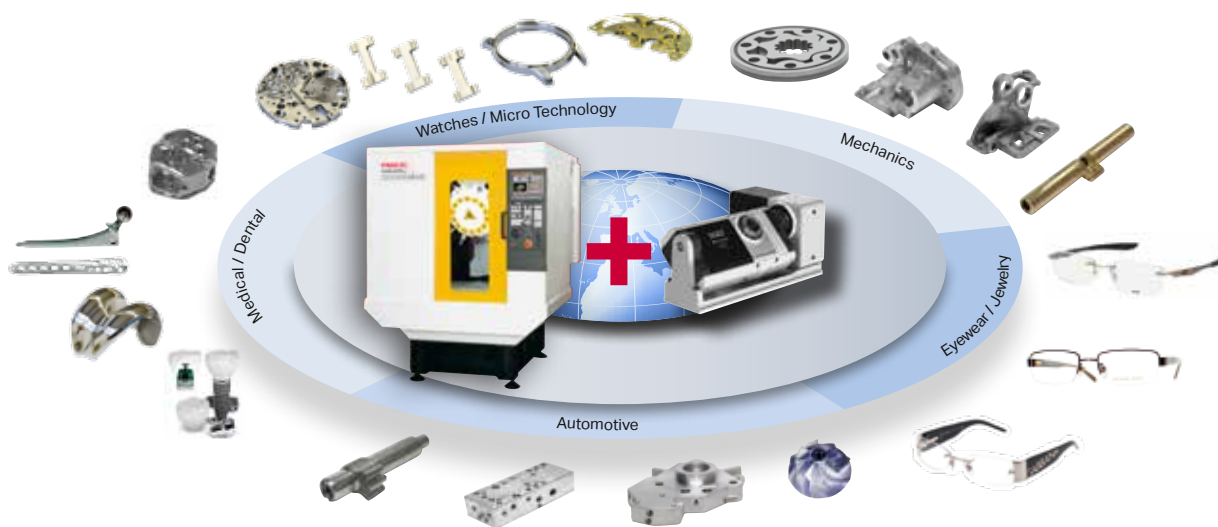

For further information refer to the master catalog or PROFi

The entire catalog is subject to technical changes in without notice



ROTARY TABLES · PRECISION TECHNOLOGY · SOFTWARE

Headquarters

PETER LEHMANN AG
CH-3552 Bârau
Telephone +41 (0)34 409 66 66
Fax +41 (0)34 409 66 00
pls@plehmann.com
www.lehmann-rotary-tables.com

Representatives / Agencies

Europe

- Austria
- Benelux
- Czech Republic
- (vacant)
- Finland
- France
- Germany
- Hungary (vacant)
- Italy
- Norway
- Poland (vacant)
- Portugal
- Russia
- Slovenia
- Spain
- Sweden
- Turkey
- UK

America

- Brazil
- Canada
- Mexico
- USA

Asia

- China
- India
- Japan
- South East Asia
- South Korea
- Taiwan

Africa

- South Africa

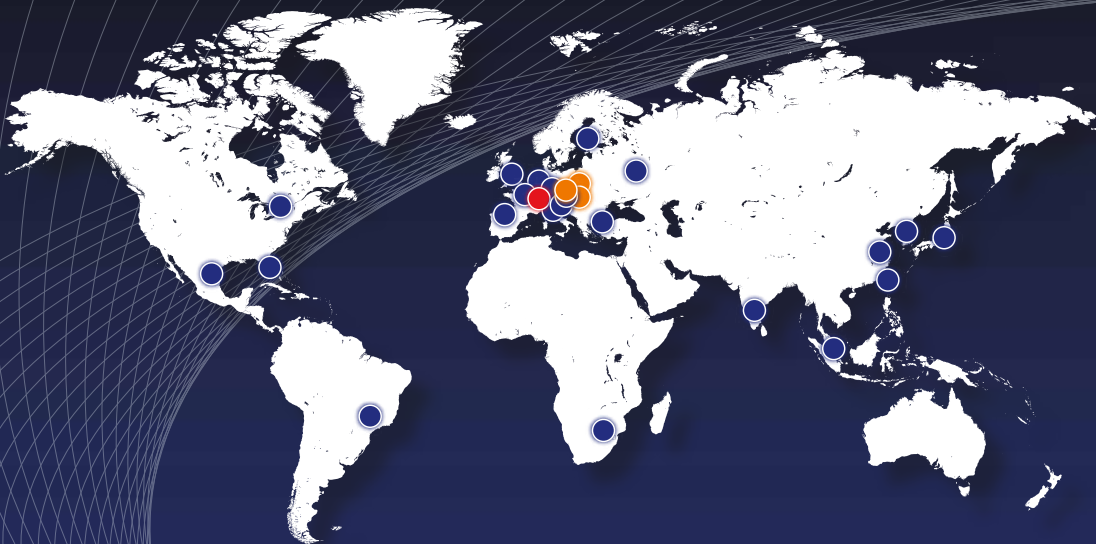

● Headquarters ● Country representatives ● vacant

More information (address, telephone number...) at www.lehmann-rotary-tables.com